

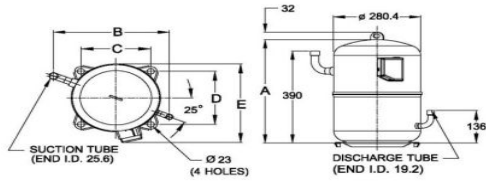

PRINCIPAL DIMENSIONS - mm



A: 454	B: 384	C: 225	D: 225	E: 334
--------	--------	--------	--------	--------

SCHEMATIC WIRING DIAGRAM -

-

SCHEMATIC WIRING DIAGRAM -

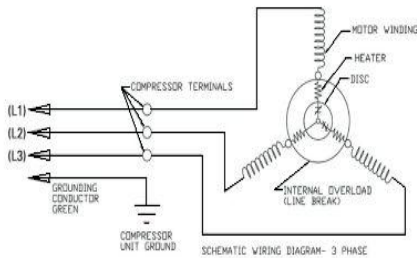

MOUNTING KIT

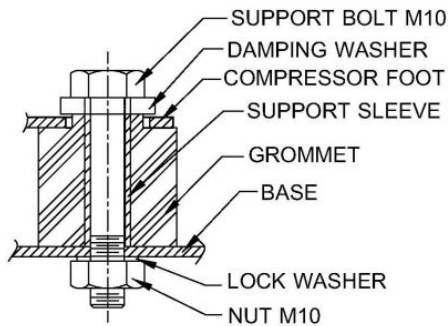

Electrical : 380-420 V/50 Hz., 440-460 V/60 Hz. 3 Phase

Nominal Performance

Capacity	28,429 / 35,170 Watts
	97,000 / 120,000 BTU/Hr
	24,446 / 30,242 Kcal/Hr
Power Input	9,800 / 12,120 Watts
Locked Rotor Amps	85.00 / 85.00 Amps
Max Continuous Current	- / - Amps
Rated Load Amps	19.70 / 21.00 Amps
COP	2.90 / 2.90 Watts / Watts
EER	9.90 / 9.90 BTU/W-Hr

Testing Conditions

Condensing Temperature	54.40 °C	129.9 °F
Evaporating Temperature	7.20 / - °C	45.0 / - °F
Liquid Temperature	46.10 °C	115.0 °F
Return Gas Temperature	35.00 °C	95.0 °F
Ambient Temperature	35.00 °C	95.0 °F

Application

Evaporating Temp. Range	HBP, A/C	@ 0.00 °C to 13.00 °C (32.0° F to 55.4° F)
	Heat Pump	- °C to - °C (- °F to - °F)
Refrigerant	R22	
Refrigerant Flow Control	Capillary tube/Expansion valve	
Compressor Cooling	Fan	

Compressor and Motor data

Compressor Type	Reciprocating
Displacement	211.00 cc.
Oil Type	Alkylbenzene
Oil Charge	3,500 cc.
Motor Type	3 PHASE ; 2 Pole 2,880 / 3,450 r/m
Voltage Range	373-456/414-506 Volts 50/60 Hz.

Winding Resistance at 25 °C

L1-L2	1.45 Ohms
L1-L3	1.45 Ohms
L2-L3	1.45 Ohms

Weight with Oil	58.89 Kg.
Weight with Oil and Accessories	59.22 Kg.

Electrical Components

Motor Protector	
Type	Internal Overload
Model Number	KLE 657-2
Open / Close	135-145 / 52-70 °C
1st Cycle trip at 25 °C	- Amps(main) 90.00 Amps(start)

Motor Starter

Type	-
Model Number	-
Pick Up (max.)	- Volts
Drop Out (min.)	- Volts
Terminal Cover	KLD 901
Start Capacitor	No µF No VAC.
Disch Resistor for Start Cap	-
Run Capacitor	No µF No VAC.

Mounting Kit

Rubber Grommet	KLD 905
Sleeve Grommet	KLD 903
Washer	-

Since we are constantly improving our product , the specification are subject to change without notice.

REV. DATE	C / N No.
08-06-12	0098/11

Certificate Marks

COMPRESSOR PERFORMANCE TABLE